

Operating Manual IRS31-UMB

Intelligent Road Sensor

Order No.: 8510.Uxxx

Status V2.3 (12/2010)



www.lufft.com



Table of Contents

1	Please read before commissioning	3
1.1	Symbols used	3
1.2	Safety instructions	3
1.3	Designated use.....	3
1.4	Guarantee.....	3
1.5	Incorrect use	3
2	Equipment description	4
2.1	Functionality.....	4
3	Installation.....	5
3.1	Preparation	5
3.2	Installation.....	5
3.3	Connecting the cable.....	6
3.4	Commissioning and testing	7
4	Maintenance	8
4.1	Replacing the sensor system	8
4.2	Connections.....	9
5	Configuration	10
5.1	Factory settings	10
5.2	Using PC configuration software	10
5.3	Firmware update.....	10
6	Communication.....	11
6.1	Binary protocol.....	11
6.2	ASCII protocol.....	13
6.3	Channel assignment for the data request	13
6.4	Mapping standards	15
6.5	Road conditions	16
7	Technical data	17
7.1	Measurements	17
7.2	Storage conditions.....	17
7.3	Operating conditions.....	17
7.4	Electrical data	17
7.5	Interfaces	17
7.6	Mechanical data	17
8	EC Certificate of Conformity	18
9	Troubleshooting.....	19
10	Service and maintenance	19
11	Disposal.....	19
12	Manufacturer.....	19

Version history:

Version	Date	Edited by	Comments
V1	09.11.2007	FS	First version
V1.1	15.10.2008	FS	Fehler in 6.2.2 / Kapitel 8 vervollständigt
V1.2	07.08.2009	SR	Chapter "Road conditions" added
V1.3	08.10.2009	SR	Temperature range extended down to -40 °C

For further information please refer to the German edition.

1 Please read before commissioning

Before using the equipment, please read the operating manual carefully and follow the instructions in every detail.

1.1 Symbols used



Important indication concerning possible hazards to the user



Important indication for the correct functioning of the equipment

1.2 Safety instructions



- Installation and commissioning must only be carried out by suitably qualified specialist personnel.
- Never take measurements on or touch live electrical parts.
- Pay attention to the technical data and storage and operating conditions.

1.3 Designated use

- The equipment must only be operated within the range of the specified technical data.
- The equipment must only be used under the conditions and for the purposes for which it was designed.
- The safety and operation of the equipment can no longer be guaranteed if it is modified or adapted.

1.4 Guarantee

The guarantee period is 12 months from the date of delivery. The guarantee is forfeited if the designated use is violated.

1.5 Incorrect use



If the equipment is installed incorrectly

- It may not function
- It may be permanently damaged



If the equipment is not connected correctly

- It may not function
- It may be permanently damaged
- There may be a possibility of an electrical shock

2 Equipment description

Road sensor IRS31 serves to monitor the road condition. It can be used to monitor the following data:

- Temperature measurement on the road surface.
In addition, 2 further temperature sensors can be attached to measure, for example, road temperatures at different depths. The calculated values do not play any part in determining the road condition.
- Measurement of salt concentration and freezing temperature
- Calculation of the water film height on the surface of the sensor

The sensor also has the following additional features:

- Compact design and easy installation
- Low maintenance
- Resistant to physical and chemical attack
- Easy to replace – even in the installed condition
- Data transfer over RS485
- Low measurement time leading to low power consumption

2.1 Functionality

IRS31 determines the road condition as a function of the measurement values.

The device operates in a temperature range from -40 °C ... $+70\text{ °C}$. The road sensor detects the conditions “dry”, “residual salt”, “damp” and “wet” above a temperature TPOS (factory setting 2 °C). Below TPOS, there are, in addition, the conditions of “freezing rain”, “frost / dry snow” and “ice / wet snow”.

The IRS31 can connect to any desired host computer which supports any of the communication protocols described in Section 6 and disposes of an RS485 interface. Measurements are polled and transmitted over an RS485 interface.

The device is connected by means of a 4-core cable.

Windows PC software is available for configuration and measurement polling during commissioning.

3 Installation

The road sensor is installed in the middle of the carriageway. If the road has two lanes, the sensor is installed in the left hand lane.

3.1 Preparation

The sensor requires a hole of diameter $D_m > 16$ cm and depth $D_p = 6$ cm. A slit of width $W = 2$ cm and depth $D_p = 5$ cm is cut into the road for the cable.



Attention! When installing on bridges, make sure that the insulation layer is not damaged (it is not always possible to maintain a depth of 6 cm in these cases).

Temperature sensor 1 (optional) requires a slit at an angle of approx. 68° to the cable slit. This slit is cut into the road with width $W = 2$ cm, depth $D_p = 5$ cm and length $L = 35$ cm.

Temperature sensor 2 (optional) requires a 30 cm deep hole with a diameter of 2 cm. This must be attached to the outer edge of the hole for the road sensor at an angle of approx. -68° in relation to the cable slit (see illustrations 2 & 3).

The external temperature sensors have IP67 protection class. Avoid permanent installation under water.

3.2 Installation

Warning: Do not undo the cable connections under any circumstances

You can only cut the cable at the control panel end.

The cable must be laid in a protective tube in such a way as to ensure that any expansion of the road covering does not affect the cable. The road sensor cables must not be subjected to tensile force during installation.



Warning: Damage to the cable sheath or external sensors causes water ingress into the sensor. Sensors with damaged cables must not be installed and can only be repaired by Lufft.

Install the road sensor in the hole provided in such a way that it is flush with the road surface. To do this, place the installation aid - which is already mounted on delivery - on the road surface. It may be necessary to align the sensor by bending the installation aid.



Under no circumstances must the road sensor project beyond the surface of the road covering (damage due to snow-clearers).

Fill the cavities with casting resin concrete.



Only use concrete bedding systems whose temperature remains below 80°C on hardening as otherwise the road sensor will be damaged.

After the casting resin concrete has hardened, remove the installation aid and the green protective film. Reinstall the fixing screws of the installation aid in the open holes of the sensor (torque 2 Nm).

3.3 Connecting the cable

The road sensor cable is connected in the control panel together with the power supply and the bus system, e. g. ISOCON-UMB.

The screening of the connection cable MUST be laid to earth.

Connection to the road sensor cable:

Brown	Positive power supply
White	Negative power supply
Green	RS485_A
Yellow	RS485_B

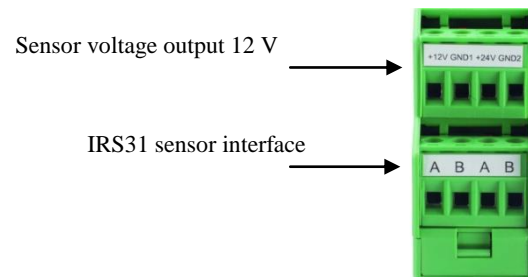

Illustration 1: ISOCON-UMB connection

Warning: Connecting the cables incorrectly will destroy the road sensor

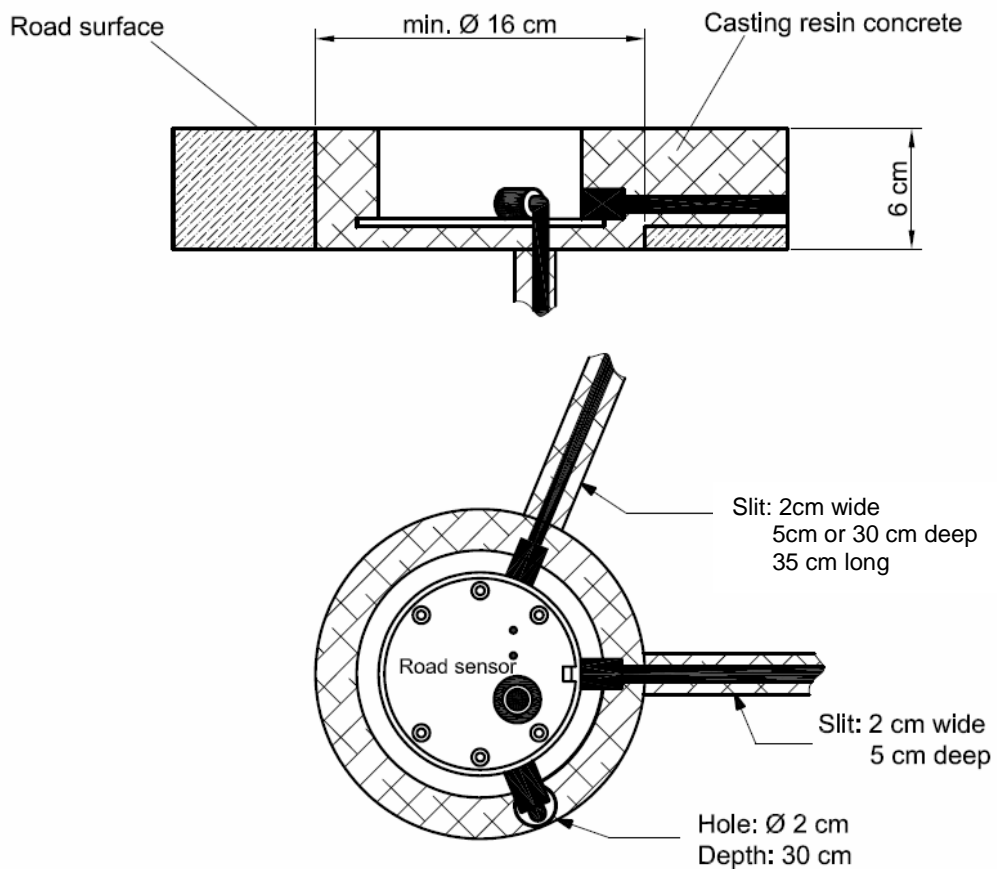

Illustration 2: Installation of IRS31 in the road

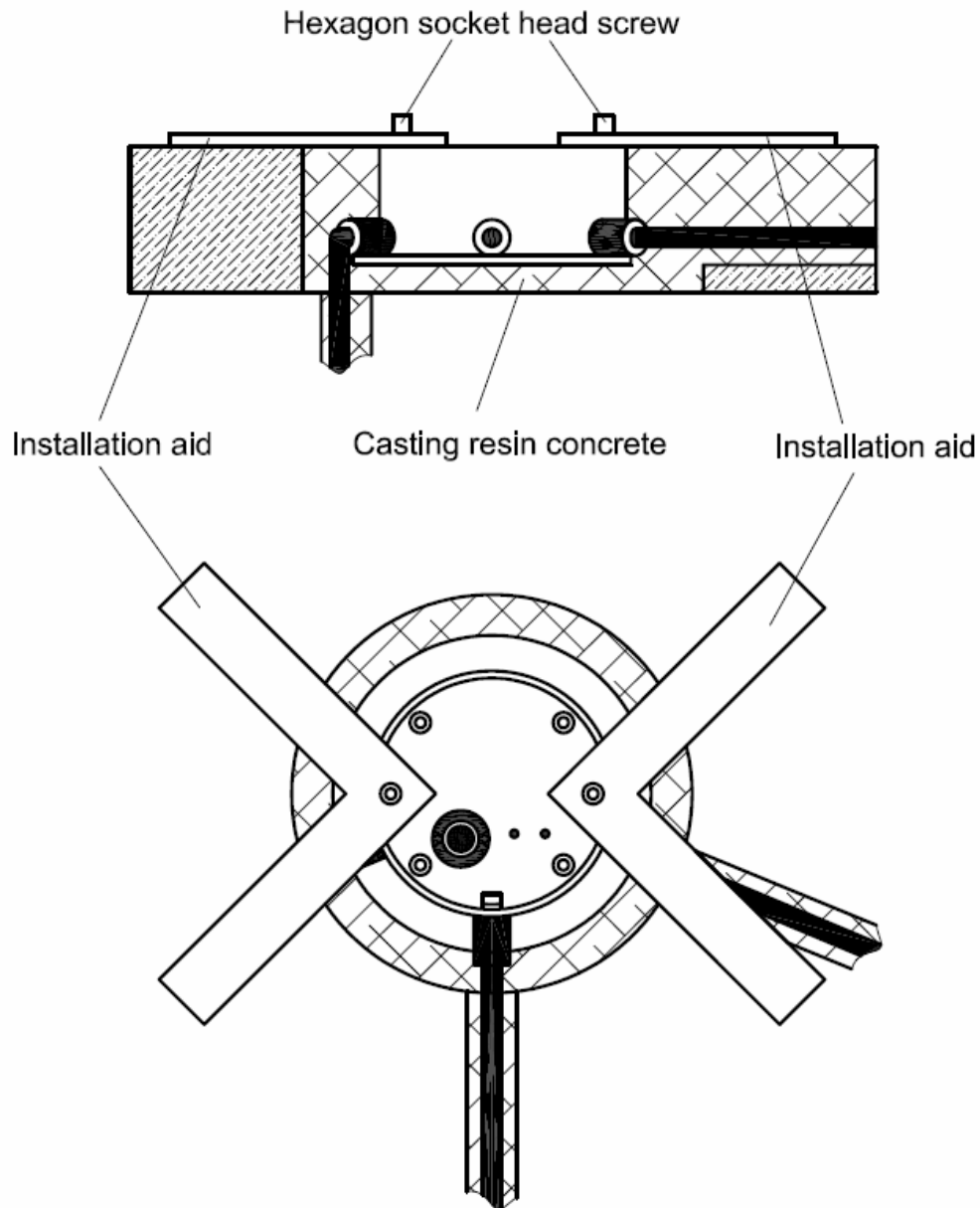

Illustration 3: Installing the IRS31

3.4 Commissioning and testing

After the device has been installed and connected correctly, initialization takes place and measurement begins.

The functionality of the road sensor must be checked after it has been installed. The sensor must be connected to an evaluation unit for this purpose. Communication between sensor and evaluation unit must be checked for perfect operation. The road condition detected by the evaluation unit must be tested with both dry **and** wet sensor.

4 Maintenance

Maintenance on the road sensor should be carried out once annually. This includes the visual inspection of the housing. It is recommended to clean the surface of the sensor if it is heavily soiled. Replacement of the sensor is recommended in the event of significant mechanical damage to the sensor which could affect the water tightness of the housing. This also applies if the sensor's plastic insert is severely worn.

4.1 Replacing the sensor system

If the road sensor's plastic insert becomes unusable due to mechanical effects, or the sensor is damaged, the plastic insert can be replaced with no need to replace the entire housing.



Attention: Only replace the sensor system when the road is dry

To uninstall the plastic insert, remove all six hexagon socket head screws. There is a small opening on the edge of the cover suitable for inserting a screwdriver. This allows you to lift out the plastic insert. Make sure that the connection cable on the underside of the sensor has not broken off. The connectors must be pulled out without putting a strain on the cable.



Important: When replacing the sensor a new seal must be fitted and a new desiccation bag inserted in each case

The housing must be cleaned thoroughly before installing the new sensor. Even small impurities on the seat of the seal can cause the sensor to fail in the long term. No moisture must be trapped in the housing. The new desiccation bag must only be removed from its sealed protected packaging immediately prior to installation. The label shows its functionality (blue: o.k., pink: the desiccation bag is used up).

On connecting the connector to the new sensor, make sure that you do not touch the sensor electronics. Electrostatic discharge (ESD) destroys the sensor.

The seal must be greased with silicone grease prior to insertion. The seal must not bend out of line on installing the plastic cover. The plastic cover must be inserted into the housing without the use of force. The threads of the fixing screws must be greased. First lightly screw in the screws and then tighten evenly (torque 2 Nm).

4.2 Connections

4.2.1 Cable

See Section 3.3 Installation – Connecting the cable

4.2.1.1 Power supply

The IRS31 power supply is 12V DC. The power supply unit used must be approved for operating devices of protection class III (SELV).

4.2.1.2 RS485-interface

The device has a half-duplex, 2-wire RS485-interface with the following settings:

Data bits: 8
 Stop bit: 1
 Parity: none
 Adjustable baud rates: 1200, 2400, 4800, 9600, 14400, 19200*, 28800, 57600
 * = factory setting and baud rate for firmware update

The screening of the cable **MUST** be laid to earth in the control cabinet

If the device is not connected properly:

- It may not function correctly
- It may be permanently damaged
- There is a danger of electric shock under certain circumstances



4.2.2 Connections in the housing

There are two, 4-pole plug sockets on the underside of the plastic insert. These serve to connect the power supply and the interface to the associated cable as well as for the optional connection of the external temperature sensors.

Power supply connection assignment/RS485 (uncoded):

- | | | |
|---|--------|-----------------------|
| 1 | White | Negative power supply |
| 2 | Brown | Positive power supply |
| 3 | Green | RS485_A |
| 4 | Yellow | RS485_B |

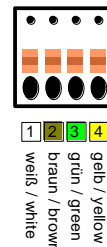

External temperature sensor connection assignment (coding pin1):

- | | | |
|---|-------|------------------------------|
| 1 | White | External temperature right 1 |
| 2 | Brown | External temperature right 2 |
| 3 | White | External temperature left 1 |
| 4 | Brown | External temperature left 2 |

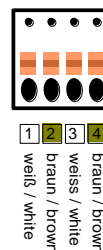

Cable labelling is based on DIN 47100.

5 Configuration

Lufft provides PC software for configuration purposes. You can set the device according to your requirements with the aid of this software.

5.1 Factory settings

The factory settings of the IRS31 are as follows:

Device-ID: 1
 Baud rate: 19200
 RS485-protocol: Binary
 Averaging interval: 10 s



If several IRS31 devices are operated on a UMB network, the ID must be changed before connection to the network, as each device requires a unique ID. IDs are allocated in ascending order, beginning with number one.

5.2 Using PC configuration software

The main functions of the configuration software are described in detail in the Online Help. For this reason only the sensor-specific menus and functions are described here.

5.2.1 Configuration

After loading an IRS31-UMB configuration, all relevant settings and values can be adjusted.

5.2.2 Channels for the measurement request

The channel for the measurement request can be activated by clicking on the respective channel.

ChNr.	Measurement	Unit	Range	Active
100	Act. Road Temperature	norm value	0.00 .. 65520.00	inactive
101	Act. Road Temperature	°C	-40.00 .. 80.00	active
102	Act. Road Temperature	°F	-40.00 .. 176.00	inactive
110	Act. Temperature 1	norm value	0.00 .. 65520.00	inactive
111	Act. Temperature 1	°C	-40.00 .. 80.00	inactive
112	Act. Temperature 1	°F	-40.00 .. 176.00	inactive
120	Act. Temperature 2	norm value	0.00 .. 65520.00	inactive
121	Act. Temperature 2	°C	-40.00 .. 80.00	inactive
122	Act. Temperature 2	°F	-40.00 .. 176.00	inactive
150	Act. Freezing Temperature	norm value	0.00 .. 65520.00	inactive
151	Act. Freezing Temperature	°C	-40.00 .. 0.00	active
152	Act. Freezing Temperature	°F	-40.00 .. 32.00	inactive

Click on Channel to toggle active

OK

5.2.3 Averaging

Via PC-Config-Software the averaging can be activated. The quantity of values which can be used for the averaging is configurable. Through the averaging the update of the channels will be extended.

5.3 Firmware update

The description of the firmware update can be found in the instructions for the UMB configuration tool.

6 Communication

Depending on the configuration of the device, the road condition can be requested in binary or ASCII protocol.

6.1 Binary protocol

This operating manual only includes one example of an online data request. Please refer to the current version of the document “**UMB Protocol**” for details of the mode of operation.

6.1.1 Framing

The data frame is constructed as follows:

1	2	3 - 4	5 - 6	7	8	9	10	11 ... (8 + len) optional	9 + len	10 + len 11 + len	12 + len
SOH	<ver>	<to>	<from>	<len>	STX	<cmd>	<verc>	<payload>	ETX	<cs>	EOT

- SOH Control character for the start of a frame (01h) 1 byte
 - <ver> Header version number, e.g.: V 1.0 → <ver> = 10h = 16d; 1 byte
 - <to> Receiver address, 2 bytes
 - <from> Sender address, 2 bytes
 - <len> Number of data bytes between STX and ETX; 1 byte
 - STX Control character for the start of payload data transmission (02h); 1 byte
 - <cmd> Command; 1 byte
 - <verc> Version number of the command; 1 byte
 - <payload> Data bytes; 0 – 210 bytes
 - ETX Control character for the end of payload data transmission (03h); 1 byte
 - <cs> Checksum, 16 bit CRC; 2 bytes
 - EOT Control character for the end of the frame (04h); 1 byte
- Control character: SOH (01h), STX (02h), ETX (03h), EOT (04h).

6.1.2 Addressing of class and device ID

Addressing takes place using a 16-bit address. This is divided into sensor class ID and device ID.

Address (2 bytes = 16 bits)			
Bits 15 – 12 (top 4 bits)		Bits 11 – 0 (bottom 12 bits)	
Class ID (0 to 15)		Device ID (0 – 4095)	
0	Broadcast	0	Broadcast
1	Road sensor	1 - 4095	Available
15	Master or control devices		

ID = 0 is provided as broadcast for classes and devices respectively. Thus it is possible to transmit a broadcast on a specific class. However, this only makes sense if there is only one device of this class on the bus.

6.1.3 Examples for creating addresses

If, for example, an IRS31 is to be given device address ID 0001, this is done as follows:
 Class ID for road sensor is 1d = 1h
 Device ID is e.g. 001d = 001h
 Putting the class and device IDs together gives an address of 1001h (4097d).

6.1.4 Example of a binary protocol request

If, for example, a request for the current water film height (0 - 10000) is to be placed from a PC to a road sensor with device ID 0001, this is done as follows:

Sensor:

Class ID for **road sensor** is 1 = 1h
 Device-ID (serial number) is 0001 = 001h
 Putting the class and device IDs together gives a target address of 1001h.

PC:

Class ID for **PC (master device)** is 15 = Fh
 PC-ID is e.g. 22 = 016h
 Putting the class and PC IDs together gives a sender address of F016h
 The length <len> for the online data request command 4d = 04h,
 the command for the online data request is 23h and
 the version number of the command is 1.0 = 10h.
 The channel number is shown under <payload>; as can be seen from the channel list, the
 current water film height 0 – 1000m in channel 601d = 259h
 The calculated CRC is 78B8h

The request to the device:

SOH	<ver>	<to>		<from>		<len>	STX	<cmd>	<verc>	<channel>		ETX	<cs>		EOT
1	2	3	4	5	6	7	8	9	10	11	12	13	14	15	16
01h	10h	01h	10h	16h	F0h	04h	02h	23h	10h	59h	02h	03h	B8h	78h	04h

The response from the device:

SOH	<ver>	<to>		<from>		<len>	STX	<cmd>	<verc>	<status>	<channel>		<typ>
1	2	3	4	5	6	7	8	9	10	11	12	13	14
01h	10h	16h	F0h	01h	10h	0Ah	02h	23h	10h	00h	59h	02h	16h

<value>				ETX	<cs>		EOT
15	16	17	18	19	20	21	22
00h	00h	FAh	44h	03h	E1h	B4h	04h

<status> = Device o.k.
 <typ> = Data type of the following value; 16h = float (4 bytes, IEEE format)
 <value> = 44FA0000h corresponds to float value 2000.00
 The water film height is therefore 2000 µm.
 Correct data transmission can be checked with the aid of the checksum (B4E1h).



Important: Little endian (Intel, lowbyte first) applies when transmitting word and float variables of such as, for example, addresses or the CRC. This means first the LowByte, then the HighByte.

6.1.5 CRC calculation

The CRC is calculated in accordance with the following rules:

Standard: CRC-CCITT

Polynomial: $1021h = x^{16} + x^{12} + x^5 + 1$ (LSB first mode)

Start value: FFFFh

(Attention: Contrary to earlier Lufft protocols, the start value for CRC calculations is not 0h but rather FFFFh in accordance with CCITT)

Further information is available in the description of a CRC calculation in UMB Protocol V1_0.

6.2 ASCII protocol

Easy communication with devices is provided by using the ASCII protocol.

ASCII protocol serves exclusively for online data requests and is not secured by a CRC.

The device does not respond to incomprehensible ASCII commands.

6.2.1 Construction

ASCII commands are introduced by the character '&' and ended with the character CR (0Dh). There is always a blank space (20h) between the individual blocks; this is represented by an underscore '_'. Characters which represent an ASCII value are in simple inverted commas.

6.2.2 Example of an ASCII request

If, for example, you want to request the current water film height of road sensor with device ID 001 from a PC, this is done as follows:

A measurement of a specific channel is requested with command "M".

Request: '&' <ID>⁵ 'M' <channel>⁵ CR

Response: '\$' <ID>⁵ '_' 'M' <channel>⁵ <value>⁵ CR

<ID>⁵ Device address (5-digit decimal with leading zeros)

<channel>⁵ Gives the channel number (5-digit decimal with leading zeros)

<value>⁵ Measurement (5-digit decimal with leading zeros); a standardised measurement from 0 – 65520d. 65521d – 65535d define various error codes

Example:

Request: &_04097_M_00601

This request polls channel 601 of the device with the address 4097 (IRS31 with device ID 0001).

Response: \$_04097_M_00601_13104

With the calculation for the water film the following calculation then results:

0d	corresponds to	0 metres
65520d	corresponds to	10000 µm
13104d	corresponds to	$10000 / 65520 * 13104 = 2000 \mu\text{m}$

6.3 Channel assignment for the data request

The channel assignment described here applies to the online data request in binary protocol.

All channels in the mapping standard are transmitted in ASCII protocol.

Channel no.	Measurement variable	Unit	Data type	Meas. range
100	Road surface	MS	unsigned short	0 ... 65520
101	Road surface	°C	float	-40 ... +80 °C
102	Road surface	°F	float	-40 ... 176 °F
110	External 1	MS	unsigned short	0 ... 65520
111	External 1	°C	float	-40 ... +80 °C
112	External 1	°F	float	-40 ... 176 °F
120	External 2	MS	unsigned short	0 ... 65520
121	External 2	°C	float	-40 ... +80 °C
122	External 2	°F	float	-40 ... 176 °F
150	Freezing temp. for Salt 1 (NaCl) ¹⁾	MS	unsigned short	0 ... 65520
151	Freezing temp. for Salt 1 (NaCl) ¹⁾	°C	float	-40 ... 0 °C

152	Freezing temp. for Salt 1 (NaCl) ¹⁾	°F	float	-40 ... 0 °C
160	Freezing temperature for NaCl	MS	unsigned short	0 ... 65520
161	Freezing temperature for MgCl	MS	unsigned short	0 ... 65520
162	Freezing temperature for CaCl	MS	unsigned short	0 ... 65520
163	Freezing temperature for Salt 4	MS	unsigned short	0 ... 65520
...
169	Freezing temperature for Salt 10	MS	unsigned short	0 ... 65520
170	Freezing temperature for NaCl	°C	float	-40 ... 0 °C
171	Freezing temperature for MgCl	°C	float	-40 ... 0 °C
172	Freezing temperature for CaCl	°C	float	-40 ... 0 °C
173	Freezing temperature for Salt 4	°C	float	-40 ... 0 °C
...
179	Freezing temperature for Salt 10	°C	float	-40 ... 0 °C
180	Freezing temperature for NaCl	°F	float	-40 ... 0 °C
181	Freezing temperature for MgCl	°F	float	-40 ... 0 °C
182	Freezing temperature for CaCl	°F	float	-40 ... 0 °C
183	Freezing temperature for Salt 4	°F	float	-40 ... 0 °C
...
189	Freezing temperature for Salt 10	°F	float	-40 ... 0 °C
600	Water film height	MS	unsigned short	0 ... 65520
601	Water film height	µm	unsigned short	0 ... 10000
602	Water film height	mil	float	0 ... 393.7
800	Salt concentration Salt 1 (NaCl) ¹⁾	MS	unsigned short	0 ... 65520
801	Salt concentration Salt 1 (NaCl) ¹⁾	Weight %	float	0 ... 100
810	Salt concentration NaCl	MS	unsigned short	0 ... 65520
811	Salt concentration MgCl	MS	unsigned short	0 ... 65520
812	Salt concentration CaCl	MS	unsigned short	0 ... 65520
813	Salt concentration Salt 4	MS	unsigned short	0 ... 65520
...
819	Salt concentration Salt 10	MS	unsigned short	0 ... 65520
820	Salt concentration NaCl	Weight %	float	0 ... 100
821	Salt concentration MgCl	Weight %	float	0 ... 100
822	Salt concentration CaCl	Weight %	float	0 ... 100
823	Salt concentration Salt 4	Weight %	float	0 ... 100
...
829	Salt concentration Salt 10	Weight %	float	0 ... 100
900	Road condition defined ¹⁾		unsigned char	0 ... 99
901	Road condition physical ¹⁾		unsigned char	0 ... 99
902	Road condition		unsigned char	0 ... 99
910	Salt content for NaCl	g/m ²	float	
911	Salt content for MgCl	g/m ²	float	
912	Salt content for CaCl	g/m ²	float	
913	Salt content for Salt 4	g/m ²	float	
...	
919	Salt content for Salt 10	g/m ²	float	
920	Salt content for NaCl	lbs p. l. mile	float	
921	Salt content for MgCl	lbs p. l. mile	float	
922	Salt content for CaCl	lbs p. l. mile	float	

923	Salt content for Salt 4	lbs p. l. mile	float	
...	
929	Salt content for Salt 10	lbs p. l. mile	float	
1049	TLS DE-Type 49 FG3 (FBT)	TLS FG3 DE 49	signed short	-300 ... +800
1052	TLS DE-Type 52 FG3 (RS) NaCl	TLS FG3 DE 52	unsigned char	0 ... 100
1065	TLS DE-Type 65 FG3 (GT)	TLS FG3 DE 65	signed short	-300 ... 0
1067	TLS DE-Type 67 FG3 (TT1)	TLS FG3 DE 67	signed short	-300 ... +800
1068	TLS DE-Type 68 FG3 (TT2)	TLS FG3 DE 68	signed short	-300 ... +800
1069	TLS DE-Type 69 FG3 (TT3)	TLS FG3 DE 69	signed short	-300 ... +800
1070	TLS DE-Type 70 FG3 (FBZ)	TLS FG3 DE 70	unsigned char	0 ... 255
1072	TLS DE-Type 72 FG3 (WFD)	TLS FG3 DE 72	unsigned short	0 ... 1000
3001	TLS DE-Type 52 FG3 (RS) MgCl	TLS FG3 DE 52	unsigned char	0 ... 100
3002	TLS DE-Type 52 FG3 (RS) CaCl	TLS FG3 DE 52	unsigned char	0 ... 100
3003	TLS DE-Type 52 FG3 (RS) Salt 4	TLS FG3 DE 52	unsigned char	0 ... 100
...	
3009	TLS DE-Type 52 FG3 (RS) Salt 10	TLS FG3 DE 52	unsigned char	0 ... 100
10000	Power supply	V	float	0 ... 18
10400	CDC-measurement	MS	unsigned short	0 ... 65520
10401	CDC-measurement	fF	float	0 ... 8192

Comments:

¹⁾ For reasons of compatibility with IRS21CON-UMB. Under certain circumstances the IRS31 does not support these channels.

²⁾ IRS21CON-UMB only.

Legend:

MS ... Mapping standard
mil ... 1 mil = 1/1000 inch

The current value transmits the currently measured value.

6.4 Mapping standards

Mapping standard	Temperature measurement range
0 – 65520	-40 - +80 °C
	-40 - +176 °F
	Water film height measurement range
	0 – 10000 µm
	0 – 393.7 mil
	Salt concentration measurement range
	0 – 100 weight %
	Capacity measurement range
	0 – 8192 fF

6.5 Road conditions

The road conditions (RDC) provided by UMB-channel 902 are shown in the following table.

RDC	Meaning
0	Dry
1	Moist
2	Wet
5	Residual Salt
6	Freezing Wet / Black Ice
7	Critical
> 90	Undefined

7 Technical data

7.1 Measurements

7.1.1 Road dampness

Unit: Dry, damp, wet

7.1.2 Slippery road conditions

Unit: No ice, snow or frost, ice

7.1.3 Road surface temperature

Principle: NTC
Measurement range: -40 ... 70 °C
Accuracy: ± 0.2 °C (-10...10 °C), otherwise ± 0.5 °C
Resolution: 0.1 °C

7.1.4 Freezing temperature

Measurement range: -20 ... 0 °C
Accuracy: ± 1 °C for $t > -10$ °C
Resolution: 0.1 °C

7.1.5 Water film

Principle: Radar
Measurement range: 0 ... 4 mm
Accuracy: $\pm (0.1 \text{ mm} + 20 \% \text{ of measurement})$
Resolution: 0.01 mm

7.2 Storage conditions

Permissible storage temp.: -40 °C ... +70 °C
Permissible relative humidity: 0 ... 100 % r.H.

7.3 Operating conditions

Permissible operating temp.: -40 °C ... +70 °C
Permissible relative humidity: 0 ... 100 % r.H.
Perm. height above sea level: N/A

7.4 Electrical data

Power supply: 9 ... 14 V DC; typically 12 V DC
Power consumption: < 200 mA
Protection class: III (SELV)

7.5 Interfaces

4-core connection cable with power supply and RS485 (2-wire, half-duplex) for configuration and measurement requests.

7.6 Mechanical data

Dimensions (W x H x D): \varnothing 120 mm - Height: 50 mm
Weight: approx. 800 g
Protection class: IP68

8 EC Certificate of Conformity

Product: Intelligent Road Sensor in combination
with UMB ISO Converter ISOCON
Type: IRS31-UMB (Order No.: 8510.Uxxx)
UMB ISO-Wandler ISOCON (Order No.: 8160.Uxxx)

We herewith certify that the above mentioned equipment complies in design and construction with the Directives of the European Union and specifically the EMC Directive in accordance with 89/336/EC and the Low Voltage Directive in accordance with 73/23/EC.

The above mentioned equipment conforms to the following specific EMC Standards:

EN 61000-6-2:2005 Part 6-2: Generic Standards – Immunity for Industrial Environments:

EN 61 000-4-2	ESD
EN 61 000-4-3	Radiated electromagnetic field
EN 61 000-4-4	Burst
EN 61 000-4-5	Surge
EN 61 000-4-6	Line-conducted interference
EN 61000-4-8	Magnetic field immunity 50Hz

EN 61000-6-3:2001 Part 6-3: Generic Standards – Emission Standard for Residential, Commercial and Light Industrial Environments
IEC / CISPR 22 Class B



Fellbach, 31.08.2007

Axel Schmitz-Hübsch

9 Troubleshooting

Description	Cause / remedy
The report will not allow polling requests.	<ul style="list-style-type: none"> - Check the power supply - Check the interface connections - False device-ID → check ID
	-
	-
	-

10 Service and maintenance

Service and maintenance should only be carried out by trained specialist personnel. The recommended service interval is 12 months.

The device must be disconnected from the power supply whilst service and maintenance work is being carried out.

11 Disposal



The device must be disposed of in accordance with European Directives 2002/96/EC and 2003/108/EC (waste electrical and electronic equipment). Waste equipment must not be disposed of as household waste. For environmentally sound recycling and the disposal of your waste equipment please contact a certified electronic waste disposal company.

12 Manufacturer

In matters of guarantee or repair please contact:

G. Lufft Mess- und Regeltechnik GmbH

Gutenbergstraße 20
70736 Fellbach

P. O. Box 4252
70719 Fellbach
Germany

Phone: +49 711 51822-0
Hotline: +49 711 51822-52
Fax: +49 711 51822-41
E-Mail: info@lufft.de
Internet: www.lufft.de

or your local distributor.